

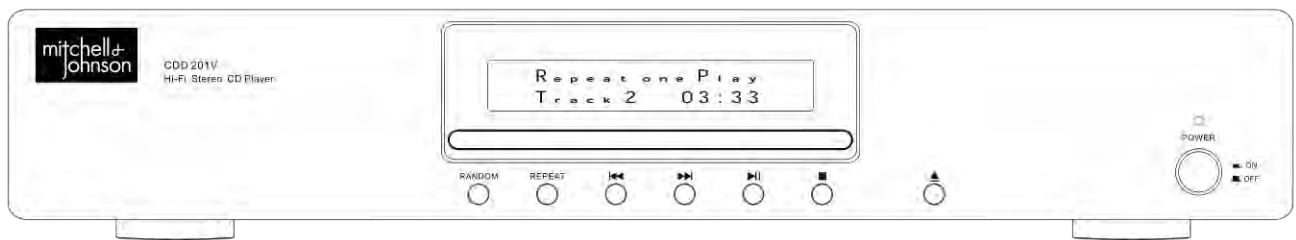

CDD201V

Compact Disc Player



User Guide

Dear Customer

Thank you for deciding to purchase this Mitchell & Johnson product. This instruction manual will give you a general idea of how this device operates, as well as providing you with information on safety procedures and cleaning. In order to maintain this product in good condition, and to ensure it's safe operation, please take a few minutes to read and carefully follow all the safety and operating instructions found in this manual.

Please retain this instruction manual for future reference and pass it along with the device if handed over to a third party. Should you have any additional questions regarding the operation or installation of this device, or should any problems arise from its use please contact a specialised dealer or our service team for further information.

We assume no liability for any damage incurred as a result of improper use resulting from failure to comply with the safety instructions found in this manual. Under such circumstances all claims under warranty will become null & void. We assume no liability for any consequential damage!

This product is EMV-certified and complies with all European and National guideline requirements. A declaration of CE conformity has been established for this product. Certification has been documented and entrusted to the manufacturer



Table of Contents

1. INTENDED USE.....	5
EXPLANATION OF SYMBOLS	5
2. SAFETY INFORMATION	6
3. ACCESSORIES.....	7
4. DESCRIPTION OF PARTS.....	8
FRONT PANEL.....	8
REAR PANEL.....	8
DISPLAY	9
MITCHELL & JOHNSON RM200 REMOTE CONTROL HANDSET.....	9
5. OPERATION	11
DISC TYPES	11
DISC HANDLING	11
6. TROUBLESHOOTING AND ERROR MESSAGES.....	12
7. MAINTENANCE AND HANDLING	13
TRANSPORTING OR SENDING THE DEVICE	13
KEEPING THE EXTERNAL CASE CLEAN	13
CLEANING THE DEVICE.....	13
8. SPECIFICATIONS.....	15







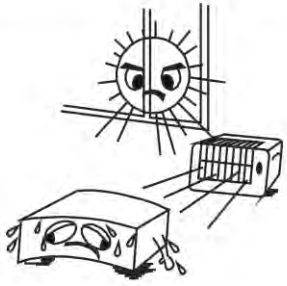

Before use

Please read this instruction manual thoroughly before operating this device and retain it for further reference. Following and heeding all the information found in this instruction manual will maintain this product in good condition and ensure its safe operation. This instruction manual contains information on how to operate and maintain this device. Should a component require maintenance, servicing or repair, then please consult a qualified dealer or service technician.

1. Intended Use

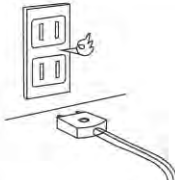
This device is a stereo compact disc player designed to play a number of different CD audio discs including CD data discs containing MP3 files.

Please adhere to all of the safety information and instructions found in this instruction manual.

 <ul style="list-style-type: none"> ● Avoid high temperatures Allow for sufficient heat dispersion when installed on a rack. 	 <ul style="list-style-type: none"> ● Keep the set free from moisture, water, and dust. 	 <ul style="list-style-type: none"> ● Do not let foreign objects in the set.
 <ul style="list-style-type: none"> ● Handle the power cord carefully. Hold the plug when unplugging the cord. 	 <ul style="list-style-type: none"> ● Unplug the power cord when not using the set for long periods of time 	 <ul style="list-style-type: none"> ● Do not let insecticides, benzene, and thinner come in contact with the set.
 <ul style="list-style-type: none"> ● Do not obstruct the ventilation holes 	<p>*(For sets with ventilation holes)</p>  <ul style="list-style-type: none"> ● Do not obstruct the ventilation holes 	 <ul style="list-style-type: none"> ● Never disassemble or modify the set in any way.

Explanation of symbols



An exclamation mark is intended to inform the user of important information, operation or maintenance instructions, or that special attention is required.



This symbol is intended to alert you to the presence of unprotected live parts or components found within the product's enclosure, or of dangerous connections that upon contact may be of sufficient magnitude to constitute a risk of electric shock. Cables intended for such connections should only be connected by qualified personnel or you should only use ready to connect cables. There are no user-serviceable parts found inside the device, therefore the device need never be opened.

2. Safety Information

The following safety and hazard warnings are not only for the protection of your device, but also serve as a protection against potential health hazards. Please take time to read the following instructions carefully.



We assume no liability for personal or property damage resulting from the failure to comply with the safety instructions, or from improper operation or handling. Under such circumstances, all claims under warranty will become void

- For safety and licensing (CE) reasons any unauthorized modification and/or changes to the device is prohibited and will void the warranty and all warranty claims.
- Any persons operating, installing, setting up, or servicing this device must be trained and qualified accordingly, and observe these operating instructions.
- Ensure that the device has been set up correctly by following all the instructions found in the instruction manual



- This is a protection class II device. Make sure that the voltage supply of the power outlet used meets the required voltage specifications 230V/~50 Hz.



- Power supply cables should be routed so that they are not likely to be walked on, squashed or pinched by items placed upon or against them. Pay particular attention to cords at plugs, power outlets, and at the point at which they exit from the device. Avoid exposing the cable to extreme heat or cold. Ignoring the above mentioned instructions could result in cable damage and present the danger of an electric shock.



- Should any obvious damage be seen on the device or on the connection cables, do not contact them in any way. Switch of the corresponding circuit breaker in the power distribution panel first, before carefully unplugging the power plug from the wall outlet. Do not operate the device further! Please contact or take it to a qualified service technician or specialty workshop.
- In order to completely cut off the power supply to the device, unplug the power plug from the wall outlet. Merely turning the device off with the ON/OFF button is not sufficient. Also make sure that power outlets are easily accessible.
- Always pull on the plug's grips and never on the cable to remove it from a wall outlet. Unplug the device from the power outlet if not in use for a longer period of time.
- For safety reasons, always unplug the device from the power outlet during thunder storms.
- Eliminate potential tripping hazards by routing cables in such a way that no one can trip or stumble over them.
- Never use the device, if the power cable or device is damaged.



- Keep packaging and protective foil away from children at all times to avoid the danger of suffocation.
- The device should never come into contact with water or moisture.
- To prevent the risk of fire or electric shock make sure that liquids, such as dripping or splashing water, rain or moisture, do not come in contact with the device and power supply plug
- Operate this device in a moderate climate and never expose it to extreme temperatures, such as high humidity.
- Condensation can build up suddenly if the device is brought from a colder area into a warmer area (e.g. when transporting). Should this happen, allow the device to warm up to room temperature first before using.
- Care should be taken so that liquids do not come in contact with the interior, this is why containers containing liquids, e.g. buckets, vases or plants should never be placed anywhere near this product, including the power supply plug. This could not only damage the device, but also present a fire hazard.
- It is imperative to avoid contact with moisture, e.g. never operate in the bathroom.
- Make sure the device is properly ventilated during operation and never operate it in constricted areas, such as for example in a bookcase or shelf. Never block ventilation openings with magazines, tablecloths, curtains or similar.
- Make sure the device is placed on a firm and stable surface.
- Never place any sources of fire on top of or near the device and power supply plug (e.g. lighted candle).
- Please note that excessive sound pressure created when listening to loud volume levels with earphones or headphones can lead to permanent hearing damage.
- Please adhere to the additional safety information found in the individual chapters of this instruction manual.
- When connecting other devices, please refer to the safety and operating instructions found in the literature accompanying the device.
- Please contact our technical hotline or a service technician for further information, should you be in doubt about device operation, safety or when making connections, or if any questions arise that are not explained within this manual.
- Contribute to a better environment by using a designated recycling site for the disposal of packaging material.

3. Accessories

The following accessories are supplied with the system. Please check all these parts are present before proceeding. Please inform your dealer if any part is missing or damaged.

1 x Remote control handset



1 x stereo left and right Phono to Phono cable for connecting to amplifier



1 x mains power cable

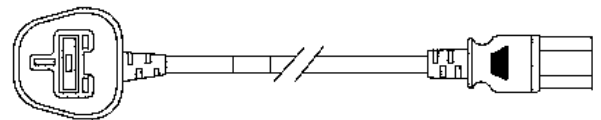

4. Description of parts

Front Panel

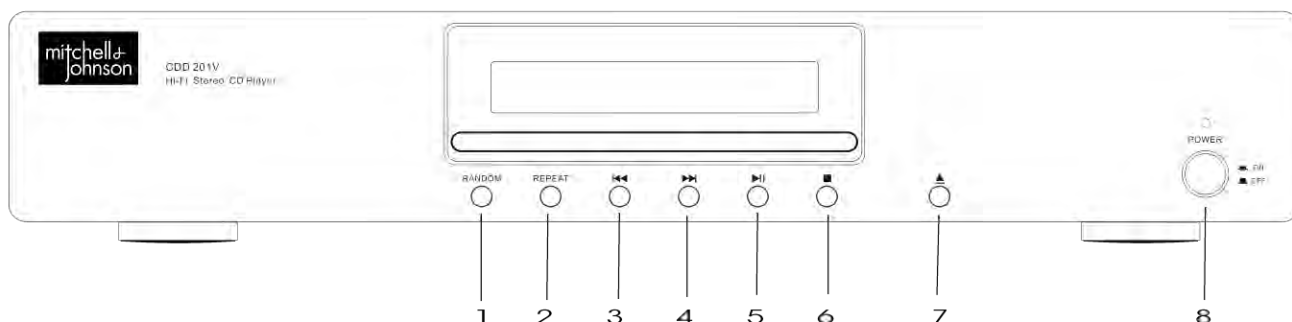

- 1 Random Play Button. Select to play tracks from CD in random order.
- 2 Repeat Play Button. Press to repeat track or entire CD.
- 3 Press to skip to previous track.
- 4 Press to skip to next track.
- 5 Play/Pause Button. Press to play and again to pause playback.
- 6 Stop button. Press to stop playback.
- 7 Eject button. Press to release CD tray. Press again to close.
- 8 Power Button. Depress to turn on power. Indicator lamp glows blue. Indicator lamp turns red if put into standby mode from remote control handset.

Rear Panel



1. Power cable inlet: Plug in the supplied power cable here.
2. Digital Optical output. Connect an optical cable (not supplied) to connect to a digital input such as the optical input on the Mitchell & Johnson SAP201V or SAV601 amplifiers.
3. Digital Coaxial S/PDIF output. Connect a COAX cable (not supplied) to connect to a digital input such as the coaxial input on the Mitchell & Johnson SAP201V or SAV601 amplifiers.
4. RCA /phono stereo output connections. Connect supplied RCA to RCA stereo pair cable ensuring the red connector on the cable is connected to the red connector on both the CDD201V and your amplifier.

Display

1. Mode Display
 - a. Play
 - b. Random
 - c. Intro
 - d. Repeat one
 - e. Repeat all
2. Track number
3. Hour
4. Minute
5. Seconds

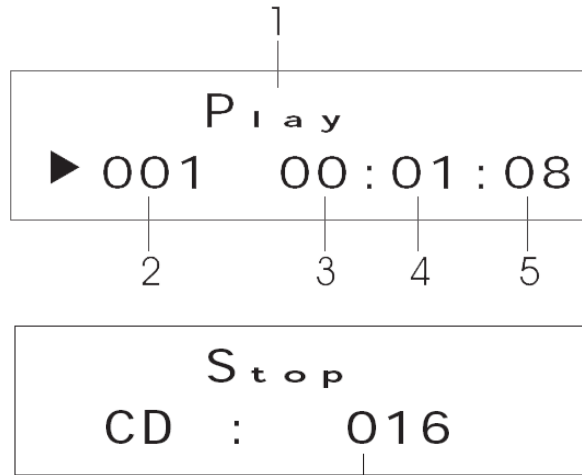

The number of total tracks.

Mitchell & Johnson RM200 Remote Control Handset

Buttons 1-6 are for controlling the **Mitchell & Johnson SAP201V amplifier**

- 1 Switch amp power to Standby or power on from Standby
- 2 Reduce Volume
- 3 Increase Volume
- 4 Mute Volume
- 5 Scroll through the Input functions on amp
- 6 Scroll through the Tone functions on amp

Buttons 7-11 are for controlling the **Mitchell & Johnson CDD201V CD Player**

- 7 Switch CD Player power to Standby or power on from Standby
- 8 Pause control
- 9 Stop button
- 10 Press to skip to previous track.
- 11 Play button
- 12 Press to skip to next track.

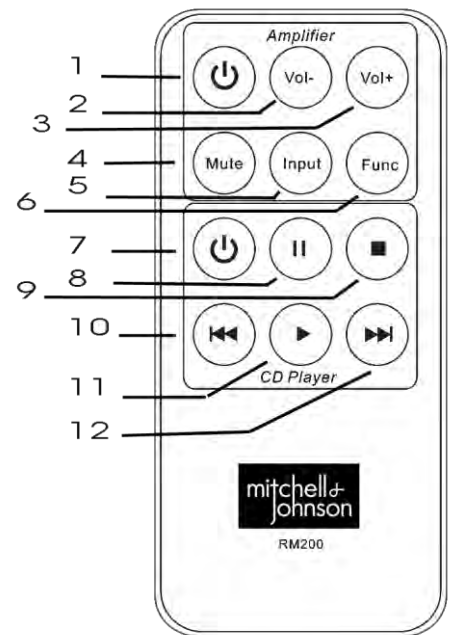

Dear Customer!



Note:

Do not throw batteries and rechargeable batteries into household waste!



Consumers are legally obligated to return used and rechargeable batteries, whether they contain harmful substances* or not, to designated recycling areas, disposal sites, or stores where batteries/rechargeable batteries can be bought. By doing so, you are fulfilling all legal battery recycling and disposal obligations and are contributing to a better environment. Make sure batteries are completely discharged before disposing!

* marked with Cd = cadmium Hg = mercuric Pb = lead

Inserting/changing batteries

Remove the battery compartment lid carefully. Remove the used batteries. Insert new batteries, observing the correct polarity as displayed inside the remote. Replace the battery lid carefully.

Information on handling batteries and rechargeable batteries

Please adhere to the following information when handling batteries and rechargeable batteries.



- Keep batteries out of children's reach.
- Batteries are hazardous and do not belong in household waste.
- Ensure correct polarity when inserting batteries.
- Always remove batteries when the remote control is not in use for long periods of time.
- Never leave batteries lying around unsupervised. If swallowed these could pose a choking hazard to children and pets. Seek emergency medical care immediately, should this happen.
- Never expose batteries to extreme temperatures, such as sunlight, fire, ovens, etc. there is a risk of explosion!
- Make sure that batteries are not dismantled, short-circuited or are thrown into fire. Never re-charge non-rechargeable batteries. There is a risk of explosion!

- Always follow the manufacturer's instructions when recharging rechargeable batteries.
- Touching leaking or damaged batteries could cause skin burns. Use protective gloves suitable for handling such batteries.
- Always ensure that the device has been turned off after use.
- Always change/replace all batteries at the same time.
- If required clean battery and device contacts before inserting,

5. Operation

Disc types

This CD player is capable of playing any pre-record compact disc bearing the following logo



In addition the following disc types maybe played:

CD, CD-R/W, CD-R-, CD-R+

The player will also playback MP3 or WMA files contained on a data CD of any above type.

Correct disc handling

Always ensure you handle any CD media with care and avoid touching the underside.

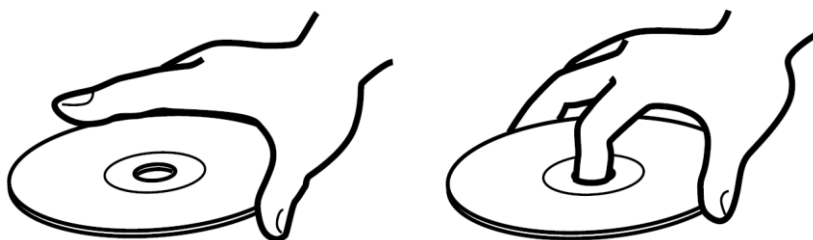

Take care when removing a CD from its case. Press the centre of the CD holder to release the disc and remove by holding the edges

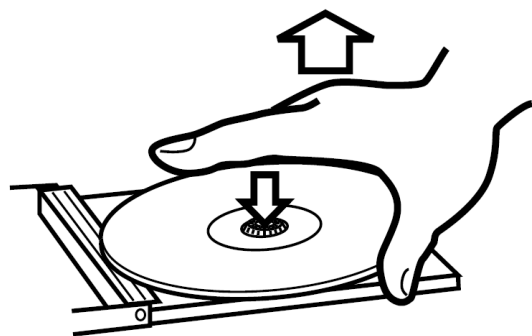

Always ensure the surface is clean and free from dust or dirt. Wipe the surface using a dry lint free cloth moving from the middle of the CD to the edge.

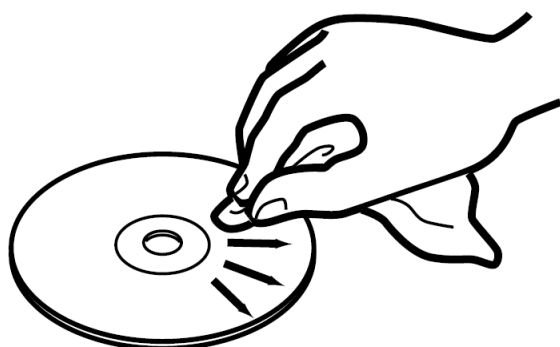

6. Troubleshooting and error messages

The CDD201V is equipped with state-of-the-art technology and is safe to operate. Nevertheless, problems or malfunctions may occur. Before contacting Mitchell & Johnson customer support, refer to the following for possible solutions.

PROBLEM	POSSIBLE SOLUTION
No power when switched on	<ul style="list-style-type: none"> - Mains socket not switched on or faulty - Plug not fully inserted into wall socket - Internal mains fuse has blown inside the unit, this will need to be replaced by a qualified service technician - Power cord has become damaged, this should be replaced immediately by a qualified technician
No sound	<ul style="list-style-type: none"> - Power not turned on - Volume setting low - Loudspeaker cables not connected - No input audio equipment is connected or is faulty - Correct audio input source not selected on front panel
No sound in one channel	<ul style="list-style-type: none"> - Audio source input cables connected incorrectly or damaged - Audio input source faulty - Loudspeaker cables connected incorrectly or damaged - Loudspeakers are faulty
Loud buzz or hum	<ul style="list-style-type: none"> - Audio input cables damaged or not correctly connected - CD player sited too close to TV
Weak bass, diffused stereo image	<ul style="list-style-type: none"> - Speaker connections out of phase check + and – terminals are connected to corresponding terminals on both amplifier and loudspeakers
Distorted sound	<ul style="list-style-type: none"> - Frayed wires may be touching on speaker terminals causing distortion - Bass and treble controls may be too high for loudspeaker specification. - Volume control may be set too high
Audio input source switches not working	<ul style="list-style-type: none"> - Internal fault would need servicing by a qualified service technician.
Remote control not working	<ul style="list-style-type: none"> - Check if the batteries have been inserted correctly. - If batteries are empty, replace them with new ones. - Remove any objects found between the remote control and the remote sensor. - Make sure the distance between the remote control and the device does not exceed 8 m
Buttons do not function (on the CDD201 and/or remote control)	<ul style="list-style-type: none"> - Turn the CDD201 off and then on again. - As an alternative, turn the CDD201 off, unplug it from the power outlet and plug in again.



Any repairs other than those mentioned above are to be carried out solely by an authorised technician.

7. Maintenance and handling

Carry out a technical safety inspection on a regular basis, e.g. check if the power cable or housing has not been damaged.

If there is reason to believe that the device can no longer be operated safely, then disconnect it immediately from the power supply and secure it against any unintentional operation. Carefully remove the power cable plug from the wall outlet and where applicable switch off the corresponding circuit breaker first.

It can be assumed that safe operation is no longer possible, if:

- there is visible damage to the device or power cable,
- the device has become wet or water has been able to get inside.
- it has been stored for a long period of time under unfavorable conditions
- Dropped, exposed to rigorous transport conditions or otherwise damaged.

Always adhere to the following safety instructions before cleaning and maintenance:



Live parts may be exposed, if the covering is opened or parts are removed.

- The device must be disconnected from the power supply source prior to service, maintenance or repairs.
- Repairs are only to be carried out by qualified personnel, who are familiar with the hazards involved and the relevant regulations.

Transporting or sending the device

Please retain the original box and the packaging material in case you need to transport or send the device out for maintenance at a later date. Please note that the device should be repacked in the original packaging. The box and packaging have been especially developed for this device in order to protect it during transport and against damage. Retain this instruction manual for future reference and where required pass it along with the device if handed over to a third party. It contains important information on initial operation and handling.

Keeping the external case clean

Never use volatile fluids near the device, as for example insect spray. Avoid letting the device come in contact with rubber or plastic products for longer periods of time. These could otherwise leave marks behind.

Cleaning the device

Unplug the power cable before cleaning. Always use a soft and dry cloth to clean the unit's exterior. If the device is extremely dirty you can use a soft cloth, dampened with water or a mild cleaning solution to clean. Never use any abrasive or harsh cleaning agents (e.g. alcohol, benzene or thinners) as these could damage the controls, casing or any markings and labels found on the device.

Important Notice

Please note that electrical and electronic devices must never be disposed of in regular household waste!

Consumers are legally obligated and responsible for the proper disposal of electronic devices by returning them to collection sites designated for the recycling of electrical and electronic equipment waste after the useful life of the device has come to an end. For more information concerning collection sites and correct disposal please contact your local authority or waste management company. The presence of the above symbol on a device, or its packaging or within the instruction manual indicates that the item must not be disposed of in normal unsorted municipal waste.

In doing so you are fulfilling all recycling and disposal obligations and are optimising and contributing to a better environment. These disposal regulations apply to batteries and rechargeable battery disposals as well. Most batteries contain hazardous chemicals which can contaminate the environment and human health if they are discarded in ordinary household waste. According to legislation batteries are to be returned to the place of purchase or disposed of at a designated recycling site

8. Specifications

- Output Level : 1.8V +/- 2dB @ 1KHz 0dB
- S/N Ratio (A): >80dB
- Power Supply : AC 230V ~ 50Hz
- Max Power Consumption: 20Watts



NOTE: Specifications and design are subject to possible modifications without notice



www.mitchellandjohnson.com

Distribué en France par
Conceptas

www.conceptas.fr