



## User Manual



Congratulations on your excellent choice of loudspeaker!

We hope that you will have a great deal of happy audio moments with your Aurelia Cerica loudspeakers for many years to come!

We recommend that you carefully read the user manual through and follow the guidelines which are provided. This will ensure that the installation and first use of the loudspeaker will be both simple and easy.

Thereafter, you will be able to confidently switch your sound reproduction equipment on and enjoy an unprecedented quality of sound.

## Stand installation

The loudspeakers are supplied with stands, consisting of a stand plate and three stand tubes. The package also includes the following parts which are required for the installation of the stand:

- |                       |           |
|-----------------------|-----------|
| - A stand pipe        | 6 pcs     |
| - Attachment screw M8 | 6 pcs     |
| - Pieces of felt      | 12 pieces |
| - Shim spacer         | 2 pcs     |

The stand is attached to the base of the loudspeaker, according to Fig 1. There is good reason at the beginning to leave the loudspeakers upside down in their packaging material, so that the screw holes on the base of the loudspeakers are visible. At this stage, remove the equipment bag and the shim spacers. The stand is attached by the following stages:

1. Remove the pieces of felt from the Velcro band and attach them to the base of the stand plate at the marked locations (see Fig 1). Each base plate should have six pieces of felt.
2. Place a shim spacer on the base of each loudspeaker, so that the plate's concave section is set against the arched base of the loudspeaker. Note should be taken that the holes on the shim spacer are set to the same location as the holes on the base of the loudspeakers.
3. Carefully tighten the stand tubes (3 pieces) adequately to the threads present on the base of the loudspeakers. **IMPORTANT!** Excessive tightening may damage the threads of both the stand tubes and the base of the loudspeaker.
4. Place the stand plate onto the stand tubes according to figure 1, so that the screw holes are positioned at the same location as the screw holes on the stand pipe. Tighten the screws to the stand tube to a sufficient tightness, using a cross-point screwdriver (Phillips). **IMPORTANT!** Avoid excessive tightening.
5. Place the loudspeaker in the upright position and move it to the listening location. **IMPORTANT!** Never lift a loudspeaker by its reflex tube.

Fig 1.

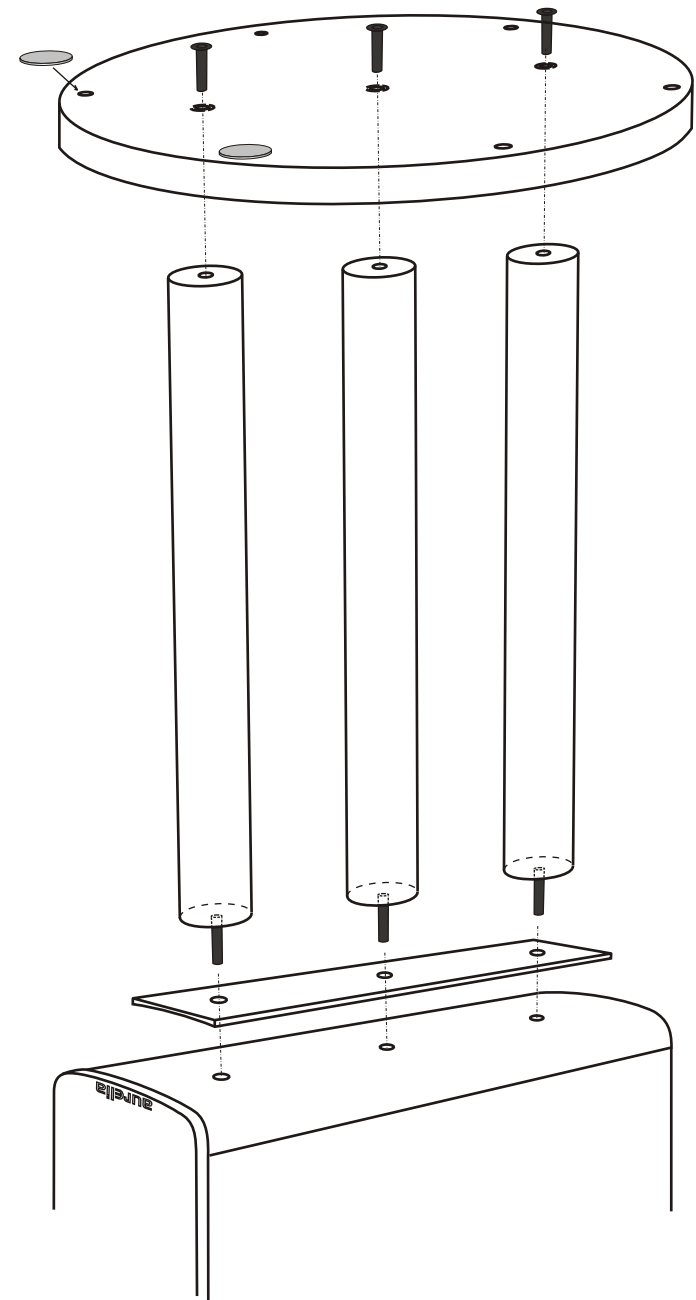

## The connection of an amplifier to the loudspeakers

NOTE! Always switch the amplifier off before connecting or disconnecting loudspeaker cables.

The loudspeakers are connected to an amplifier through the connections and speaker cables, located behind the loudspeakers. The right loudspeaker is connected to the amplifier's right channel (R) and the left loudspeaker is connected to the left channel (L).

Fork connectors or banana plugs can be used when connecting the loudspeakers. The cables can also be connected to the loudspeakers without connectors, by unpeeling the insulator of the loudspeaker cable for about 10 mm and placing the peeled end in the hole on the side of the connector. The connector screw is rotated open thus that the hole alongside the connector screw becomes visible. The cable is placed in the hole and then the screw is tightened to an appropriate hand tightness.

A spanner may also be used for the tightening process. In this case, note should be taken that excessive tightness is not used. The black jack is the (-) pole and the red is the (+) pole. The (+) lead from the loudspeaker is attached to the amplifier's (+) terminal and the (-) lead to the (-) connector.

IMPORTANT! Make sure that the (+) and (-) connectors, leads or their cords do not come into contact with each other, as the amplifier may be damaged. Carefully tighten the connectors so that the cables do not later become loose, possibly resulting in a short circuit. Also, read the user manual for the amplifier to ensure that the connectors to the loudspeakers have been completed correctly.

## Presence-switch

The Aurelia Cerica has switch located on the rear panel, which can be used to fine-tune the tonal balance of the speaker.

The Presence-switch affects the upper frequency range of the loudspeakers. When the switch is in the upright position, the sound of the loudspeaker is brighter and "more present" than when the switch is in the downwards position. The correct positioning for the switch is determined according to the users' own personal preference.

The switches at the respective appropriate position have an effect on the acoustics of the room, the used front end (amplifier, audio source, etc.) as well as the audio recordings. For example, when using a tube amp, a higher position may perform better, whilst a lower position, when used with solid state amplifiers, can often prove to be a practical decision.

The Presence switch is an excellent tool for fine-tuning the balance of the sound, at the same time fine-tuning the placement of the loudspeakers in the listening room.

## The positioning of loudspeakers in the listening area

Aurelia Cerica speakers are more directional than ordinary speakers and therefore, their positioning in the listening area is easier than normal. Due to the directionality, sound reflected from walls, the floor and the ceiling is less than normal and as a result of this, high standard sound can also be enjoyed in locations which are acoustically difficult.

The best quality of sound is achieved when the loudspeakers are placed far enough away (min. 50 cm) from the room walls, corners, or other surfaces. The loudspeakers should, if possible, be positioned in such a way that they are equal distance from the listener. The distance between the loudspeakers should be about  $2/3$  of their distance from the listening position (Fig 2).

Wider positioning could be tested in softer room acoustics. Generally, it is not recommended to place the speakers farther apart, than their distance from the listening position. It is worthwhile thus, to place the loudspeakers so that the elements are directed towards the listener. In some cases, better results can be achieved by turning the loudspeakers away from the listener, slightly outwards from the shoulder line (Fig 3).

The positioning can affect the clarity of the upper treble. If a darker sound is desired, turn the loudspeakers outwards from the listener, whilst turning the loudspeakers towards the listener will attain a brighter sound. The form, size, building materials and interior decoration of the listening location also have a significant affect on the sound. The most appropriate location for the loudspeakers is found through personal listening and experimenting.

Fig 2. Positioning of speakers in the listening area

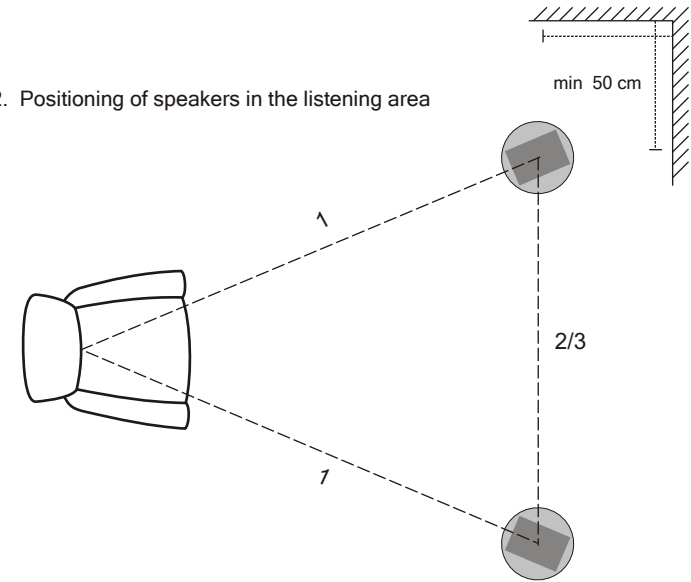
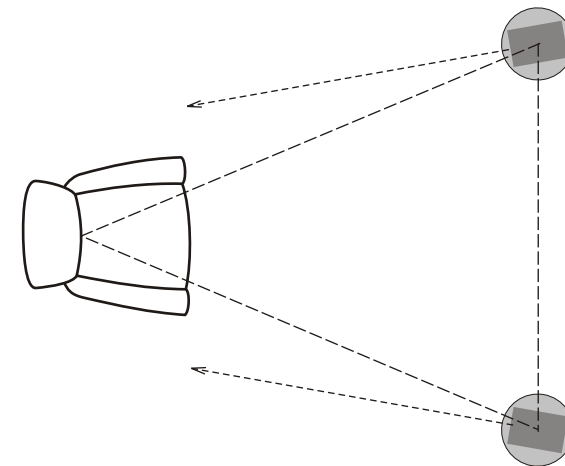

Fig 3. Turning the speakers outwards from the listener



## Reflex tube blocking

The blocking of the reflex tubes is recommended in the event that the loudspeakers are placed close to a wall and / or the bass reproduction is accentuated. If a subwoofer is used with the loudspeakers, the best and most uniform sound is often attained when the reflex tubes are blocked.

## Cleaning the loudspeakers

When cleaning the surface of the loudspeakers, we recommend using a dry microfiber cloth. To remove difficult stains, the cloth can be moistened with water and when necessary, a mild soapy solution. When using a cleaning fluid to clean a painted or polished surface, there is reason to first try the rear plate of the loudspeaker to ensure that the surface of the loudspeaker is not damaged. For cleaning an aluminium profile, we recommend that the same substances are used as when cleaning painted and varnished surfaces.

## Fault situations

All Aurelia loudspeakers are measured, tested and checked at the factory during their manufacture. If an error nonetheless occurs with the loudspeakers, they should be returned to the relevant retailer.

The most common cause of faults are improper cable connections. Ensure that the cabling and connections are made correctly. In the event that no sound can be heard from the loudspeakers, you can check the functionality by switching it to an operating loudspeaker channel. If, in this event, the loudspeaker works, the fault is in another location than the loudspeaker. In so far as the speaker remains silent, it is possible that the speaker has been damaged.

## Warranty

The warranty of the loudspeaker is five (5) years, from the date of purchase. The warranty covers faults resulting from the manufacturing process and materials, but not damages as a result of incorrect use of the product. The most common fault caused by incorrect use is related to damage to the tweeter element by an audio level which is too high. Also the bass units may be damaged when excessive volumes levels are used.

In so far as the sound of the loudspeaker becomes distorted, it may a sign of an excess volume level. In this case, the volume must be lowered immediately. The warranty does compensate for damages caused by audio levels that are too high.

The opening or removal of the loudspeaker's elements, connector panel or any other part will result in the warranty becoming invalid.

## Technical specifications

Operational principle	2-way bass reflex
Tweeter element	3 x 25 mm titanium, CSR
Bass element	2 x 140 mm DDC Isomatrix
Crossover frequency	1500 Hz
Impedance	8 ohm
Sensitivity	86 dB
Frequency Response	40-20 000 Hz, -6dB
Recommended amplifier power	15-300 W
Dimensions mm (H x W x D)	545 x 145 x 350
Weight	16.0 kg

**aurelia loudspeakers**

Tel +358-44-5303935

[info@aurelia.fi](mailto:info@aurelia.fi)

[www.aurelia.fi](http://www.aurelia.fi)

aurelia is a registered trademark, owned by ASL Technosystems OY

Aurelia est distribué en France par ConceptAs  
[www.conceptas.fr](http://www.conceptas.fr) - [contact@conceptas.fr](mailto:contact@conceptas.fr)